

EARTH-FAULT INDICATOR

TYPE **EFL**

panel-mounted

General description

The earth-fault indicator type EFL is a cost-efficient fault indicator that can be used in radial medium voltage networks with one input and open-ring networks. The network has to be solidly earthed or low resistance-earthed. The indication of the earth-fault is done by an LED indicator. The connection between the earth-fault sensor and the display unit is done by cable. The sensor must be mounted on screened cables. It is divisible and can be retrofitted on the cable. The display device is powered by an exchangeable lithium battery with a lifetime of approx. 20 years with 1000 blinking hours. The earth-fault indicator type EFL can reset automatically by recovering 230V AC. The EFL is available in three versions so that it can be used very cost-efficiently according to the demand. The following table shows a version comparison:



Display unit

Subject	EFL basic	EFL scada	EFL plus
single trip current	X	X	
single response delay	X	X	
adjustable trip currents (selection of 5 trip currents)			X
adjustable response delays (selection of 4 response delays)			X
adjustable reset times (selection of 2 reset times)			X
automatic reset by 110 / 230 V AC	X	X	X
automatic reset by recovering net current (enabled / disabled by DIP switch)			X
remote indication contacts NO/NC (permanent contact)		X	
remote indication contacts NO/NC (permanent/wipe contact, selectable by DIP switch)			X
remote reset		X	X
external blinking lamp			X





Sensor type SE

General Data

Version	Subject	Value
EFL basic / EFL scada	earth-fault trip current (phase to ground)	one value selectable: between 10A and 300A ($\pm 10\%$)
	response delay	one value selectable: between 40ms and 300ms
	reset of the indicator	a) manual by push-button b) time: one value between 1h and 16h ($\pm 1\%$) after fault c) by recovering 230V AC
EFL scada	SCADA contact	1 x NO and 1 x NC permanent contact max. 230 V AC / max. 2 A / max. 30 W
EFL plus	earth-fault trip current (phase to ground)	adjustable: 25 / 50 / 75 / 100 / 125 * A ($\pm 10\%$)
	response delay	adjustable: 40 / 60 / 80 / 160 * ms
	reset of the indicator	a) manual by push-button b) time: adjustable 4h / 8h ($\pm 1\%$) after fault c) by recovering 230V AC d) by recovering net current
	SCADA contact	1 x NO and 1 x NC permanent / wipe contact (100 * ms) (contact type can be selected on site by a dip switch) max. 230 V AC / max. 2 A / max. 30 W
indication unit		suitable for panel installation low installation depths
on site function test		by push-button
indication of earth-fault		red LED, flashing 1 time / second
dimensions: indication unit		(WxHxD) 97 x 48 x 29 mm (dimensions of the cut out: 92+0.8 x 45+0.6 mm / IEC 61554 / DIN43700)
Protection class: sensor		IP67
internal type test		according to IEEE 495-2007
operation temperature range		-25°C to +70°C
power supply		lithium battery (LiSOCl ₂) type AA / 3.6V / 2600 mAh
earth-fault sensor (CT)		one earth-fault sensor type SE (current transformer for a three-core cable or three single-core cables) diameter: 80-100* mm connection cable length: 3* m (copper cable)

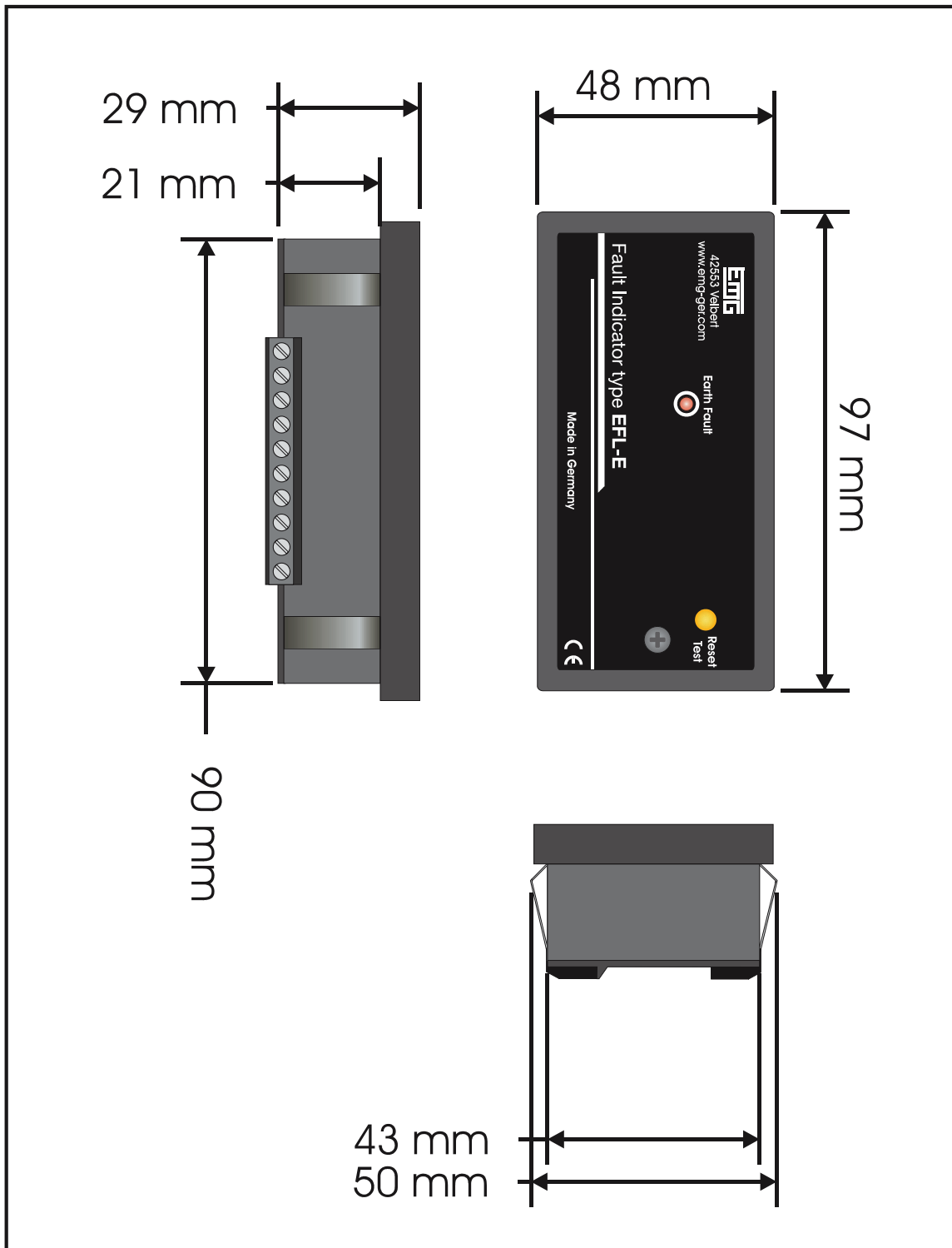
*Please note: The values shown are standard values. Other values can be ordered.



Maßstab/scale: 1:1	Name: Fault indicator type EFL-E	Erstellt am/von: D. Kusserow/ created on/by: 09.09.2013
 Elektro-Mechnik GmbH 42553 Velbert Germany	Status: <input type="checkbox"/> ungültig/invalid Ersetzt durch/replaced by: XX.XXXX.XX	Zeichnungsnummer/ drawing number: 27.1754.00

